

Product specification

catalogue

1. Overview	1
1.1 Operating environment and parameters	3
1.2 Attention information	4
2. Control panel operation guide	5
2.1 Welding mode	6
2.2 Cutting mode	14
2.3 Cleaning mode	14
2.4 Welding seam cleaning.....	19
3. Maintenance	20
4. Common exception handling.....	20
4.1 Warning of laser / water cooler / air pressure alarm	20
4.2 Screen not bright / click not responsive	20
4.3 No light	21
4.4 Suddenly stop producing light during processing.....	21

Thank you for choosing the four-in-one system, and this user manual provides you with important safety, operation, maintenance and other information. Therefore, please read this user manual carefully before using this product.

To ensure safe operation and optimal product performance, follow the following precautions and warnings and other information in this manual.

1. Overview

This manual covers the basic installation, factory setting, operation and maintenance services of SUP series 23T model.

SUP23T Four-in-one hand welding head is a new super great application in handheld laser welding, non-contact welding, welding cleaning, cutting field of single motor scanning swing welding head —— hereinafter referred to as SUP23T. The product includes a handheld laser head and its control system, and has multiple safety alarms and active safety light break settings. It is developed on the basis of the SUP20T handheld laser head which has been mass produced by our company. Compared with the previous generation, it is further improved in insulation, stability, maintenance and other aspects, and has the characteristics of more compact, lighter and more reliable.

The product can be adapted to various brands of fiber lasers, optimized optical and water cooling design so that the laser head can work stably for a long time at 3000W, and the cleaning width of switching cleaning mode is up to 120mm.

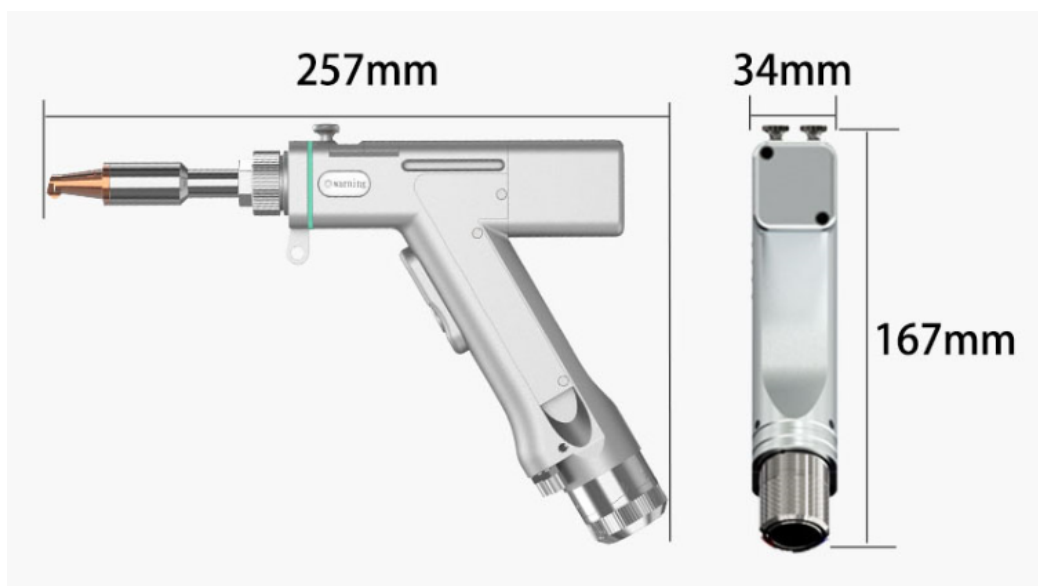

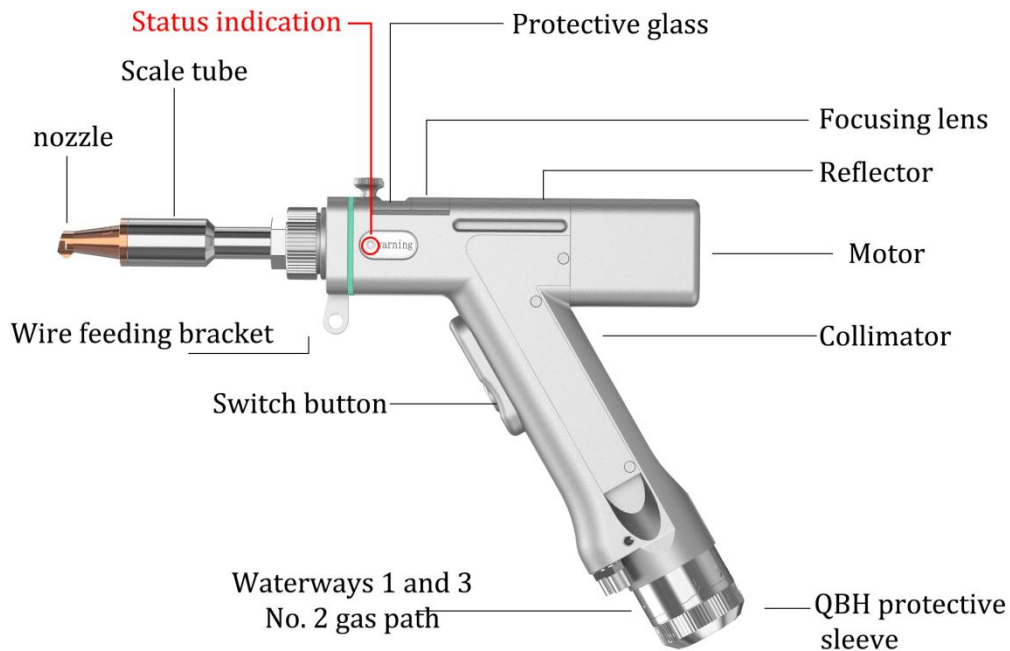

Figure 1.1 Schematic diagram of the SUP-23T welding head

Product features:

- Basic features of the product: self-developed control system and structural design, adapt to various welding requirements within 3000W, set multiple safety alarms and state indicator lights, abnormal state instantaneous response. The net weight of 750k is flexible and easy to use.
- The whole machine is more stable: all parameters can be seen, monitor the state of the whole machine in real time, avoid problems in advance, facilitate troubleshooting and troubleshooting, and ensure the stable operation of the hand-held welding head.
- Subversion structure design: the main structure integrated design and processing, greatly reduce the failure rate, and facilitate the later maintenance.
- Controlled parameters and high repeatability. Stable nozzle pressure and lens state, as long as the laser power is stable, the process parameters must be repeated, save the adjustment time, improve the work efficiency.

1.1 Operating environment and the parameters

As shown in Table 1.1, the operating environment requirements and main parameters of SUP23T:

Table 1.1 Operating environment requirements and main parameters of SUP23T

input voltage (V)	1.5/2KW:220V±10% AC 50/60Hz
	3KW: 380V±5% AC 50/60Hz
Installation environment	Flat, no vibration and impact
Working environment temperature: (°C)	10~40°C
Working environment humidity: (%)	<70%
cooling-down method	hydrocooling
Applicable wavelength	1064nm (±10nm)
Applicable power	≤3000W
alignment	D16*4.5/F60
focus	D20*4.5/F150
reflex	30x14xT2
Protection mirror specifications	D18*T2
Maximum air pressure support	15Bar
Focus of vertical adjustment range	±10mm
Scan width-weld	0~8mm
Scan Width-Wash	F150-0~30mm
	F400-0~60mm
	F800-0~120mm
The net weight of the gun	0.75kg

1.2 Pay attention to information

(1) Ensure reliable grounding before power supply.

(2) The laser output head is connected with the hand-held laser head through QBH, please carefully check the laser output head to prevent dust or other pollution. Please use special lens paper when cleaning the laser output head.

(3) If the equipment is not used according to the method specified in the manual, it may be in an abnormal working state and lead to damage.

(4) When replacing the protective mirror, please ensure good protection.

(5) Please note: for the first time, when the red light can not come out of the copper mouth, be sure not to shine.

(6) State indication: the gun body [state indicator light] is ①, red flashing

indicates that the —— water cooler alarm, laser alarm, air pressure alarm, can not shine at this time.②, The red light indicates that the —— protection mirror over temperature alarm, the motor driver over temperature alarm, at this time the equipment is in an abnormal state can force light, should be stopped for inspection.

2. The Control Panel Operating Guide

SUP-23T handheld welding head control panel version number is V5.8-802-801, the version number is subject to the physical picture for reference only.

Supported languages: 19 languages.

Simplified Chinese	English	Korean	Russian
Traditional Chinese	Japanese	Dervin	French
Italian	Spanish	Portuguese	Turkish
Greek	Czech	Slovak	polish
Thai	Vietnam	Romania	

Table 1



Figure 3.0–Language switching

2.1 Welding mode

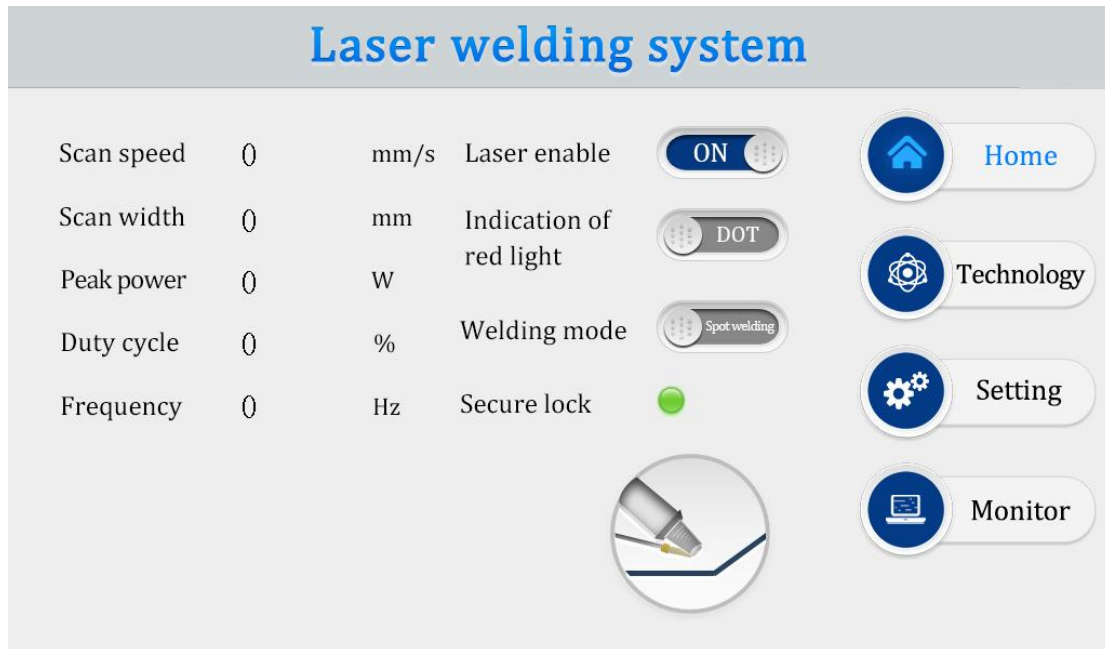

Figure 2.1-1, the front page of the control panel

- ① This interface can see the current process parameters (this page can not be modified process) and real-time alarm information.
- ② The default is ON, the red light is LINE by default, and the welding mode is continuous. When the enabling is turned off, the enabling signal will not be sent to the laser and can be used to test the outlet function. Close the red light indicator, the motor stops swinging, and the red light is a point to adjust the center position. The welding mode is divided into continuous and spot welding. When the spot welding is selected, the spot welding type needs to be set on the setting page.
- ③ The safety lock is divided into gray and green. When the metal clip is clamped on the processing piece and the copper nozzle of the gun contacts the processing piece, the 5 and 6 feet of the signal interface 1 are connected, and the safety lock indicator is displayed as green. At this time, the light can be realized according to the trigger.

- ④ Click on the upper right corner to switch to the cleaning mode.

The current process page provides 10 process items for users to save parameters. The definition and scope of process parameters are described below:

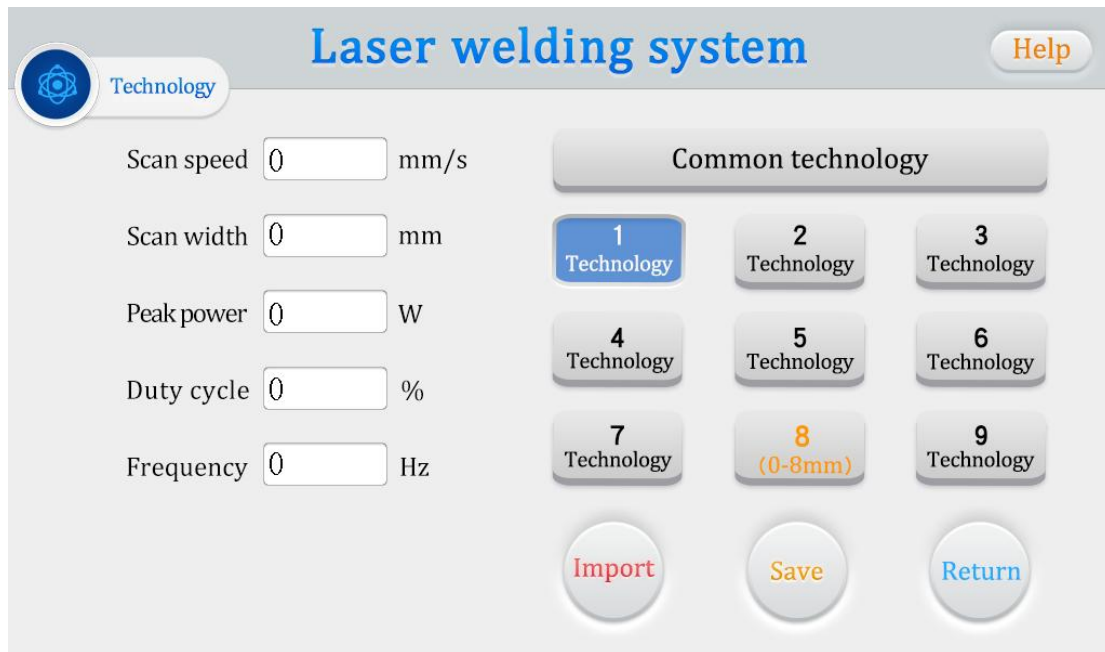

Figure 2.1-2 Control panel process page

- ① The process interface contains the process parameters of debugging, click the box (red) to modify, click OK, and then save in the quick process, click import (modify-save-import).
- ② The scan speed range is 2-6000mm / S, and the scan width range is 0 ^ 6mm. The scan speed is limited by the scan width, which is: $10 \text{ scan speed} / (\text{scan width} * 2) 1000$ If the limit is exceeded, it automatically becomes the limit value. When the scan width is set to 0, it does not scan (ie, a point light source)
(The most commonly used scanning speed: 300mm / S, width of 2.5-4mm).
- ③ The peak power should be less than or equal to the laser power of the parameter page (if the laser power is 1000W, this value is not higher than 1000).
- ④ Duty cycle range 0 to 100 (default 100, usually not changed).
- ⑤ The pulse frequency range is recommended from 5-5000Hz (default 2000, usually no modification).
- ⑥ Click the HELP button on the top right to get more relevant parameter explanations.

⑦ After modifying the parameters, you can see whether the import is successful on the home page

⑧ Reference process, can be used in the small program process reference

matters need attention:

① Some lasers cannot emit light with less than 10% power. When the peak power of the process page is less than 10% of the maximum power of the laser on the set page, all output signals are normal, but they may not emit light.

② The duty cycle is 100%, usually does not need to change, when the pulse frequency does not work. If you need to use it, please adjust it according to the actual requirements. Example: Peak power of 300W, duty cycle of 50%, and pulse frequency of 1000Hz. At this time, the light cycle is 1mS,0.5mS to 300W light, 0.5 mS does not light, the cycle, the air at the welding burst, abnormal sound is normal phenomenon. The actual situation is based to the laser parameters.

③ Click on the Help button at the top right of the screen to get more relevant parameters.

④ More reference process, can be viewed in the process of WeChat small program.

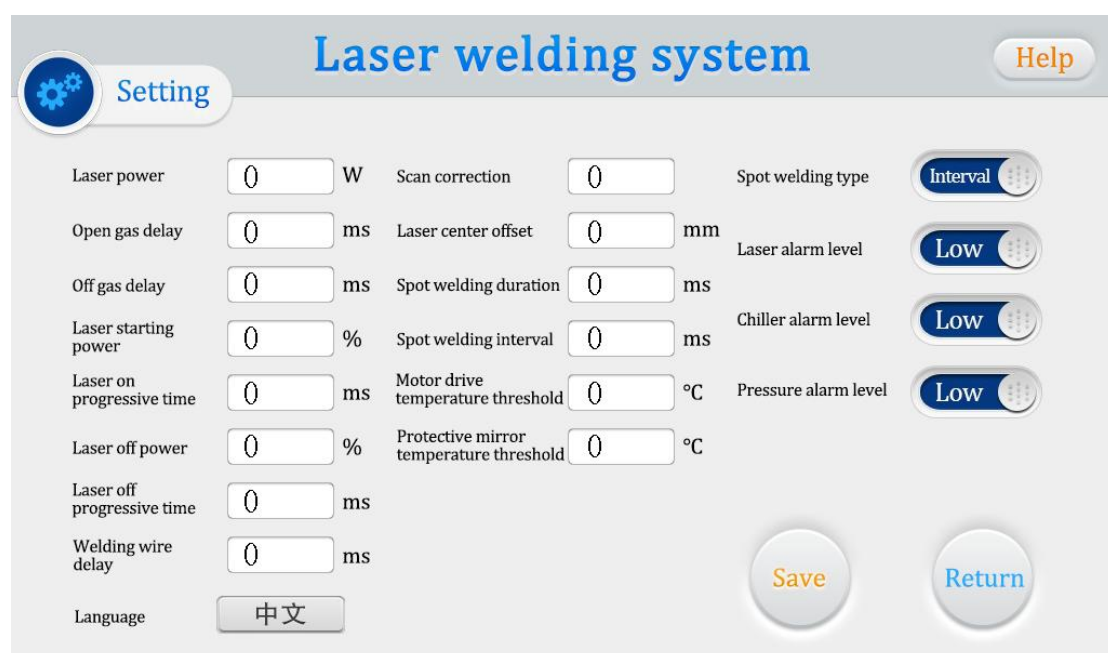
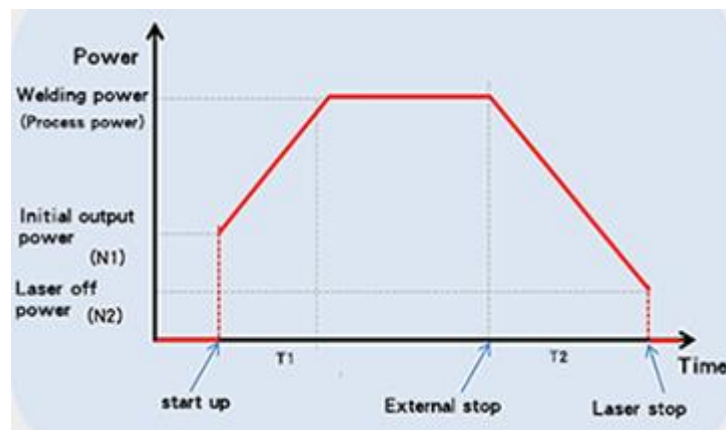

Figure 2.1-3 Control Panel setting page

Click "Settings" on the home page, enter the password 123456 on the password input page of the pop-up window, and then enter the Settings page.

- ① The laser power is the power of the used laser, please fill in correctly.
- ② The default air delay default 200ms, range 0 ms to 3000 ms.
- ③ From N1% of process power to 100%; from 100% of process power to N2; (as shown in the figure below):



graph 2.1-4

Generally preset switch light power 20%, switch light step time 200ms;

④ Silk delay compensation is the advance time relative to the light signal, which can be used with the withdrawal function, not set by default;

⑤ The maximum value of the three temperature alarm valves is 70°C. When the value is set to 0, the temperature is not detected, and the buzzer alarms when the measured temperature is greater than the set value;

⑥ Scan correction coefficient = target line width / measured line width, range from 0.01 to 4. Generally set to 1;

⑦ Laser center offset-3~3mm, decrease to the left, increase to the right, applied to adjust the red axis light center;

⑧ Air pressure / water cooler / laser alarm level signal is low level, and when this alarm signal is used, the alarm level here should be set to the same with the alarm level of external equipment;

⑨ The spot welding duration is the light output time in each cycle in the spot welding mode, and the spot welding interval time is the light stop time in each cycle in the spot welding mode;

⑩ Click on the Help button at the top right to get more relevant parameter explanations.

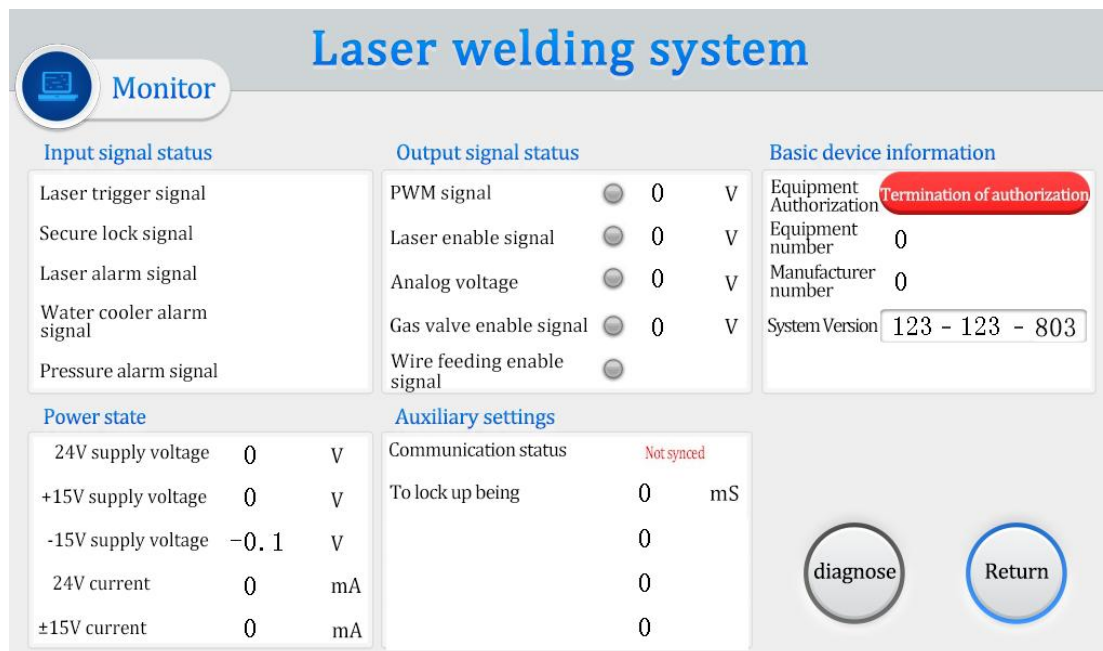

Figure 2.1-5 Monitoring page

This page displays the status of each signal and the equipment information.

① Input signal status

Laser trigger signal: when the user externally controls the 7 and 8 feet of the signal interface 1, this state is changed from gray to green.

Safety lock signal: normal short contact, this state changes from gray to green.

Laser / water cooler / air pressure alarm signal: monitor the real-time level status of these interfaces.

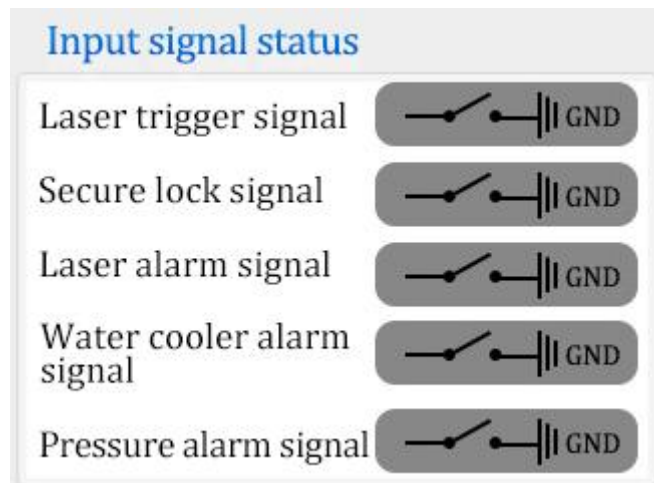

Figure 2.1-6 Monitoring page-Input signal status bar

② Output signal status

When the signal is output, the signal in this area changes immediately and can be directly visualized. The monitoring signal is the circuit signal detected in real time, which will fluctuate in a certain range and have an error of less than 0.3V with the final output signal.

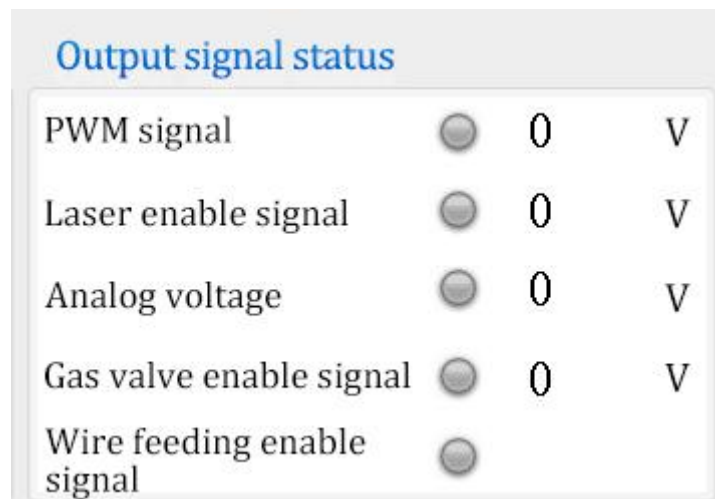

Figure 2.1-7 Monitoring page-Output signal status bar

③ Basic information of the equipment

Equipment authorization: click to encrypt the use time of the equipment. When the equipment is used for more than the set time, the authorization will be terminated and the system will stop working. Factory default is long-term effective, if you need encryption and decryption, please contact us for inquiry.

System version: three sets of numbers, the first group is the hardware version, the second group is the microcontroller program version, the third group is the touch screen version.

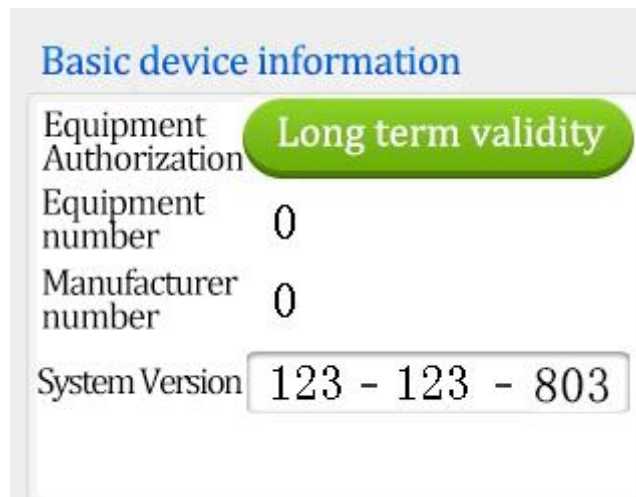

Figure 2.1-8 Monitoring page-Set up the basic information bar

④ power status

The real-time power supply voltage and current of the device are shown. Due to the update of the algorithm, the data accuracy continues to indicate that there will be some differences in different versions of different versions, which is a normal phenomenon. Mainly through the power supply voltage to help after-sales power supply troubleshooting.

Power state		
24V supply voltage	0	V
±15V supply voltage	0	V
-15V supply voltage	-0.1	V
24V current	0	mA
±15V current	0	mA

Figure 2.1-9 Monitoring page-Power status bar

⑤ communication status

“Communication status” indicates the communication between the touch screen and the motherboard. If not synchronized, check the screen cable.

“Anti-shake” is used to deal with poor contact with safe locks, which range from 0 to 300 ms. Click “Device authorization box” to set the parameter range on the password page as shown in Figure 3.9. The password is “ffffffaa300” where “ffffffaa” indicates the lock anti-shake parameter and cannot be changed. “300” means 300ms. The effect is that when the trigger signal is normal and the disconnection time of the safety lock signal is <300ms. Material welding used to deal with poor surface performance and unstable conductivity (e. g. rust) is usually set to 0.

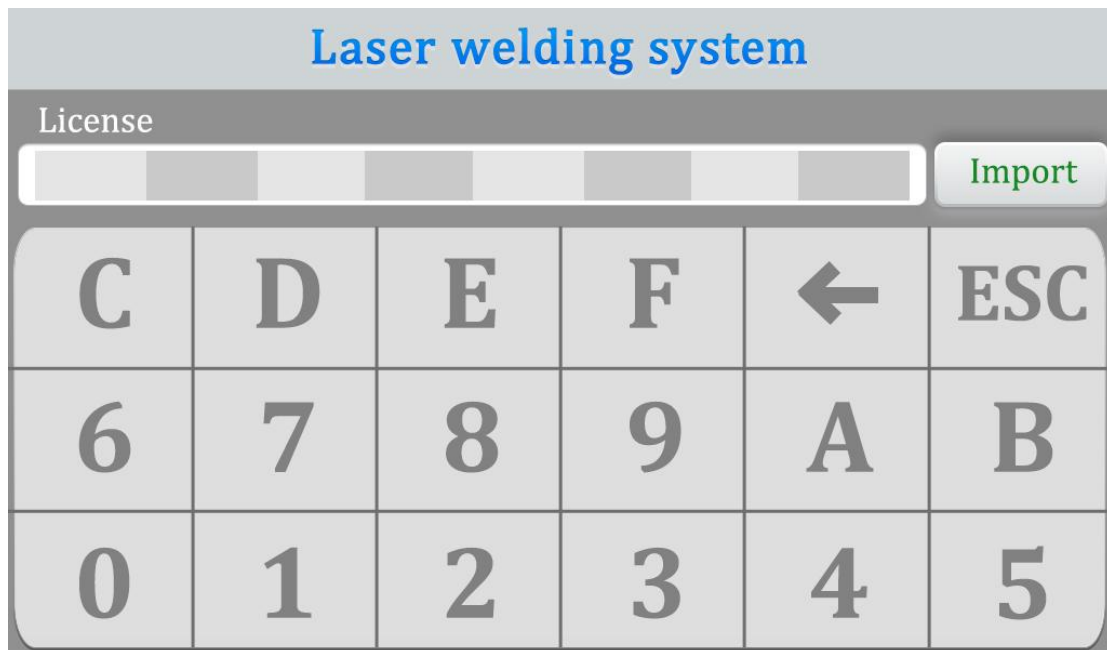

Figure 2.1-10 Monitoring page-auxiliary status bar-ground lock anti-shake password

“Motor driver temperature” and “protective mirror temperature” represent the measured real-time temperature of the two parts. “Motor driver temperature” affects the motor swing performance of the environment. If the environment is poor, it will lead to the abnormal temperature increase, affect the laser scanning speed, and then lead to the decrease of weld

quality. The lens temperature reflects the working state of the lens to help determine whether the lens is damaged.

Auxiliary settings		
Communication status	Not synced	
To lock up being	0	mS
Motor drive temperature	0	°C
Protective lens temperature	0	°C

Figure 2.1-11 Monitoring Page-Auxiliary status bar

⑥ diagnose

Click the diagnostic button to enter the diagnostic interface. Use to measure whether the signal port has an actual output, usually the output value is consistent with the detection value. When inconsistent, the load is abnormal, such as when the laser does not light, through the single port with the laser monitoring software or multimeter measurement, the real reaction signal is emitted



diagnose

Laser welding system

Output signal	Theoretical output value	Detection value	Switch control
PWM signal (V)	0	0	
Laser enable (V)	0	0	
Gas valve enable (V)	0	0	
Analog voltage (V)	0	0	
Wire feeding enable	<input type="checkbox"/>	Observe the status of the wire feeder or measure with a multimeter	

Return

Figure 2.1-12 The diagnostic page

2.2 Cutting mode

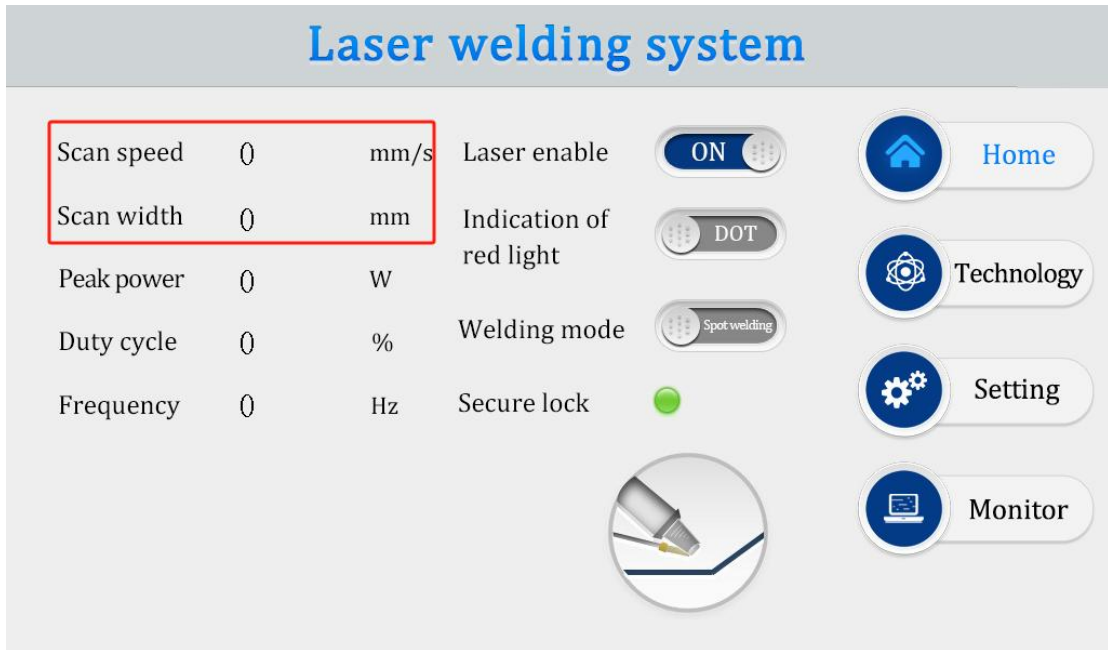

graph 2.2-1

[Scan width] is set to [0], which refers to the [copper mouth] for replacing cutting, which can be cut.[safe ground lock] needs to be ensured.

2.3 Cleaning mode

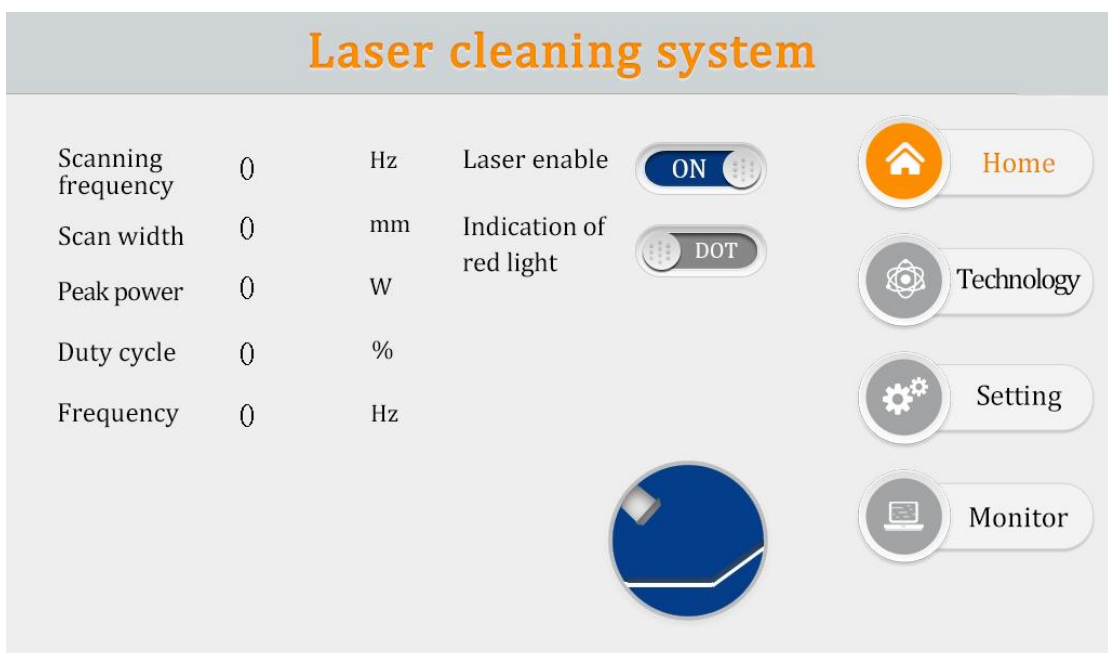

graph 2.3-1

① This interface can see the current process parameters (this page can not be modified process) and real-time alarm information.

② The default state is ON, indicating that the red light is LINE by default. When the enabling is turned off, the enabling signal will not be sent to the laser and can be used to test the outlet function. Close the red light indicator, the motor stops swinging, and the red light is a point to adjust the center position.

③ Click on the upper right corner to switch to the cleaning mode.



graph 2. 3-2

① The process interface contains the process parameters of debugging, click the box (red) to modify, click OK, and then save in the quick process, click import (modify-save-import).

② The scan frequency range is 10-100 HZ, and the scan width range is 0 ^ 30mm.

(At the focusing lens F800, the maximum width is 130mm. At the focusing mirror F150, the maximum width is 30mm).

③ Peak power should be less than or equal to the parameter page laser power. (If the laser power is 1000W, then this value is not higher than 1000).

④ Duty cycle range 0 to 100 (default 100, usually not changed).

⑤ The pulse frequency range is recommended from 5-5000Hz (default 2000, usually no modification).

- ⑥ Click the "Help" button on the top right to get more relevant parameters explained.
- ⑦ After modifying the parameters, you can see whether the import is successful on the home page.
- ⑧ Reference process, can be used in the small program process reference.

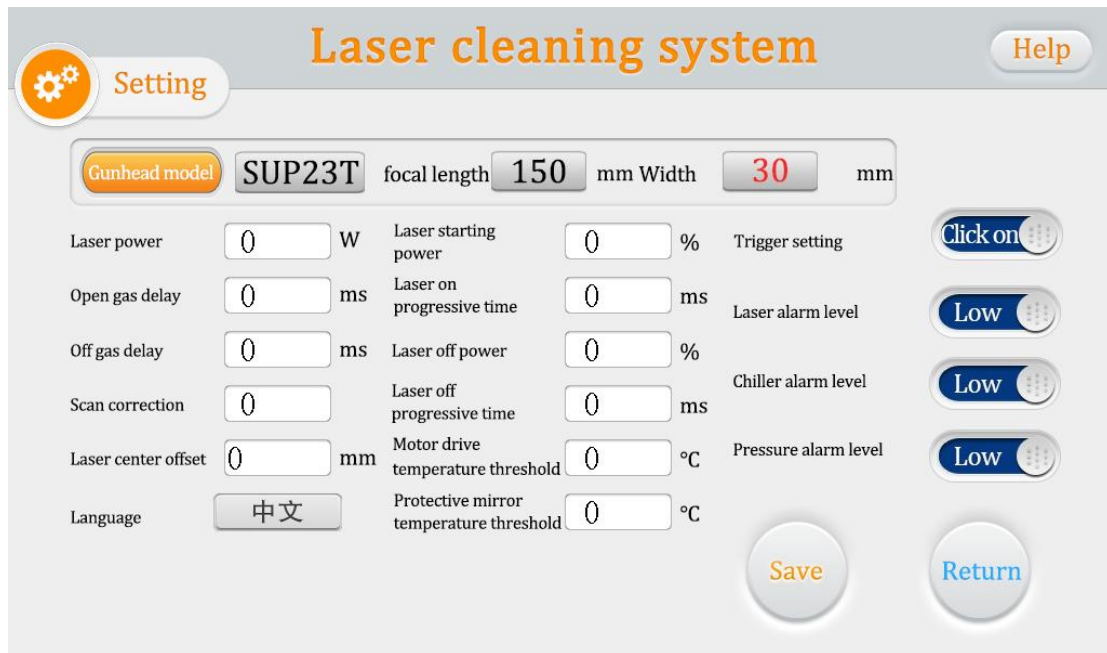

graph 2. 3-3

Password: 123456

- ① The laser power is the power of the used laser, please fill in correctly.
- ② The default gas delay default 200ms, range 200ms-3000ms.
- ③ From N1% of process power to 100%; from 100% of process power to N2; (as shown in the figure below).

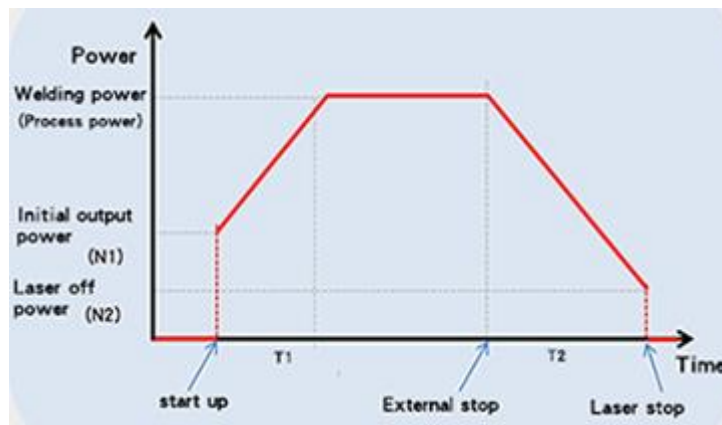

graph 2. 3-4

The higher the process power, the lower the recommended open light power. Open light power usually should not exceed 50%, too high open light power will greatly reduce the service life of the lens.

④ The maximum temperature alarm valve value is 65°C. When the value is set to 0, the temperature alarm is not detected.

⑤ Scan correction coefficient range 0.01~4, coefficient target line width / measured line width: the default is 1.0.

⑥ Laser center offset: The cleaning mode only shows the current offset. If you need to adjust the center, please cut back to the welding mode, and replace the F150 aggregation mirror to ensure accuracy.

⑦ The pressure / water cooler / laser alarm level signal is low level by default. When this alarm signal is used, if the external pressure alarm is installed, it will be changed to high level, otherwise there will be abnormal alarm will occur, and other alarm signals should be the same.

⑧ Click the "Language" button, you can switch to other languages in the language selection bar. Currently, the standard version supports 19 languages. Please contact us if necessary.

Factory reset

Laser cleaning system

✕

1. Please set the maximum scan width according to the actual gun head model and focal length of the focusing lens.
2. "Laser power" refers to the maximum power of the laser, please fill in the actual laser power value.
3. The range of "Gas Opening delay" is 0~3000ms, and 200~500ms is recommended.
4. The range of "Gas off delay" is 0~3000ms, and 200~500ms is recommended.
5. The scanning correction coefficient=target linewidth / measured linewidth, range is from 0.01 to 4.
6. "Laser center offset" range: -3mm ~ 3mm, please replace the F150 lens in welding mode adjustment.
7. The maximum temperature alarm threshold is 70 °C, and when the value is set to 0, the temperature alarm is not detected;
8. Trigger setting: set the trigger to emit light by single-click or double-click.

graph 2. 3-5

⑨ Click "Help" in the upper right corner to enter the help page of the Settings page. Long press "Restore factory Settings" to restore the setting parameters to the factory state. Long press "Save as factory settings" to modify the factory parameters.



graph 2. 3-6

⑩ Click "Gun size number" to focus the mirror to select the maximum scanning width.

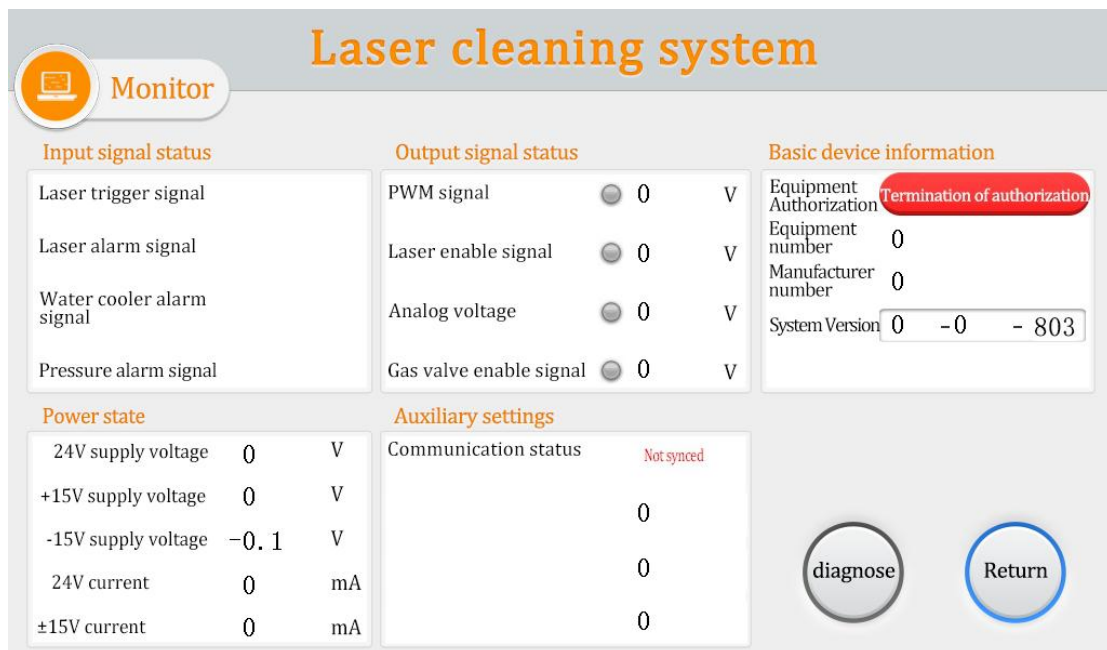

graph 2. 4-1

This page displays the status of each signal and the equipment information
 Laser trigger signal: when the trigger is pulled, this state changes from gray to green
 Laser / water cooler / air pressure alarm signal: monitor its set high and low levels

The output signal is shown in the middle of the page, colored green when the signal is output

Equipment authorization: the equipment can be authorized, when the equipment is used over the set time, the authorization shall be terminated,

System version: three groups of numbers, the first group is the hardware version, the second group is the microcontroller program version, the third group is the touch screen version



graph 2. 4-2

Click the Diagnostic-button to enter the diagnostic page. Under this page, the laser will not emit light, you can control the independent output "PWM", "laser enabling", "air valve enabling" and "analog amount" through the "switch control", and compare the detection value to judge the theoretical value of the control box function is normal.

2.4 Welding seam cleaning

Change the [AS-2.0D] copper nozzle in welding mode. For the specific process, see the wechat small program demonstration video

3. Maintenance

Maintenance and replacement method of related lenses:

- ① Before the operation, please clean your hands and dry them first, and then wipe your hands again with cotton dipped in alcohol.
- ② Open the protective mirror in a relatively dust-free place, focus the mirror compartment cover, pull out the lens bracket, do a good job of protection (beautiful paper cover), check the protective lens, if there is an obvious burning point on the lens surface, should be directly replaced.
- ③ Then check the white storage seal ring under the lens.(If the storage sealing ring cannot be used, it must be replaced immediately.
- ④ Wipe the warehouse mouth and the inside of the warehouse cover with a cotton ball dipped in alcohol, quickly insert the protective lens bracket into the protective mirror compartment, and lock the screws.

4. Common exception handling

4.1 Warning of laser / water cooler / air pressure alarm

- ① If the above alarm does not using the alarm signal, please change the alarm level of screen setting page.
- ② If the alarm appears in the above alarm signal, check whether the alarm or the high and low level of the alarm signal is set correctly

4.2 Screen not bright / click not responsive

- ① The screen is not bright, make sure the controller is powered on. Check whether the controller and the four-core wire of the screen are connected correctly, and whether the voltage of foot 1 and 4th foot 24V is normal.
- ② If not clicked in normal use, check whether the temperature of the machine is too high.

③ Click unable to input, check whether the wiring between the controller and the screen is correct, and whether the second and third feet are normal. See 2.1.2 controller display end for details.

④ Newly installed equipment click no reaction may be the system version does not match, use the SD card to rebrush the program can be, please ask us for the specific version.

4.3 No light

① Check whether there is an alarm prompt on the home page, and whether the laser enabling system is ON;

② Check whether the trigger signal and safety lock signal of the monitoring page are displayed in green during welding;

③ Check whether the PWM, laser enabling and analog output of the monitoring page are normal during welding.

If the above conditions are normal, check the laser for abnormal alarm.

Example: the air supply wire but not the light, for the laser fault or laser wiring error. If neither air nor wire supply, the input signal may be missing, see: 2.1.3 Controller signal interface 1.

4.4 Suddenly stop producing light during processing

Check whether the safety ground lock and other alarm of the monitoring interface are normal.